

Technical Manual

Contents

| Section 2 Characteristics | | |
|----------------------------------|--|-----------|
| 1 | General | 18 |
| 2 | Material composition | 18 |
| 3 | Physical properties | 19 |
| | (1) Summary | 19 |
| | (2) Specific gravity | 19 |
| | (3) Thermal expansion/contraction | 19 |
| | (4) Thermal conductivity | 20 |
| | (5) Deflection temperature | 20 |
| | (6) Sound transmission loss | 20 |
| | (7) Vibration damping | 21 |
| 4 | Mechanical properties | 21 |
| | (1) Mechanical properties of ACM | 21 |
| | (2) Mechanical properties of aluminum skin | 21 |
| | (3) Rigidity and panel weight | 22 |
| | (4) Impact resistance | 22 |
| | (5) Bendable limit | 23 |
| 5 | Applied properties | 23 |
| | (1) Heat transmission | 23 |
| | (2) Non-permeability | 24 |
| | (3) Fire performance | 24 |
| 6 | Coating performance | 28 |
| | (1) Color variation | 28 |
| | (2) Coating system | 28 |
| | (3) Coating performance | 28 |
| 7 | Panel strength | 29 |
| | (1) Calculation of permanent deformation | 30 |
| | (2) Calculation of panel deflection | 30 |
| | (3) Strength of joining hole | 31 |
| | (4) Strength of sub-structure | 31 |
| 8 | Lightning and earthquake | 31 |
| | (1) Lightning | 31 |
| | (2) Earthquake | 32 |

Section 2 Characteristics

1. General

As mentioned in the previous section, ALPOLIC and ALPOLIC/fr are Aluminum Composite Materials (ACM) composed of aluminum sheets and the polyethylene core or the fire-retardant core. We will introduce various properties of ALPOLIC and ALPOLIC/fr in this section. These properties are summarized in “Appendix 1: Summary of specification data” in Section 4, too.

ALPOLIC and ALPOLIC/fr are often simply referred to as “ALPOLICs” or “ALPOLIC products” in this brochure, when the context is applicable to both products. We will use the respective ALPOLIC and ALPOLIC/fr, if we need to mention each of them separately.

2. Material composition

ALPOLICs are composed of aluminum skins and a core material. The material compositions of the standard products are listed in Table 2-1. This technical manual is about the standard products listed in Table 2-1.

Table 2-1 Material composition

| Product | Thickness mm | Component thickness, mm | | | Aluminum material | Core material | |
|------------|-----------------|-------------------------|------|----------|-------------------------------|---|-------------------------------------|
| | | Aluminum | Core | Aluminum | | | |
| ALPOLIC/fr | 3 | 0.5 | 2.0 | 0.5 | Aluminum alloy 3105-H14 | Non-combustible mineral filled core | |
| | 4 | 0.5 | 3.0 | 0.5 | | | |
| | 6 | 0.5 | 5.0 | 0.5 | | | |
| ALPOLIC | 3 | 0.5 | 2.0 | 0.5 | | Aluminum alloy 3105-H14 | Low-density polyethylene core |
| | 4 | 0.5 | 3.0 | 0.5 | | | |
| | 6 | 0.5 | 5.0 | 0.5 | | | |

Note 1 (Total thickness): 8mm thick ALPOLICs are available as a custom-order. Please contact local distributors or our office for details.

Note 2 (Aluminum thickness): ALPOLIC/fr composed of 0.3mm thick aluminum skins is a standard product as ALPOLIC/fr LT. Refer to the ALPOLIC/fr LT brochure for details. ALPOLIC composed of 0.3mm thick aluminum skins and a polyethylene core is available as a custom order. Please contact local distributors or our office for details.

Note 3 (Skin material): ALPOLIC/fr composed of different metal skins is available as TCM, SCM and ZCM. Refer to the separate brochure of the respective products.

Note 4 (Foamed polyethylene core): AL-LEADER is composed of a foamed polyethylene core to further decrease the weight. Refer to the separate brochure for details.

3. Physical properties

(1) Summary

The following table is a summary of physical properties of ALPOLICs.

Table 2-2 Summary of physical properties

| Physical properties | Method | Unit | ALPOLIC/fr | | | ALPOLIC | | |
|--------------------------------------|-----------|-----------------------|------------|------|------|---------|------|------|
| | | | 3mm | 4mm | 6mm | 3mm | 4mm | 6mm |
| Specific gravity | - | - | 1.99 | 1.90 | 1.81 | 1.52 | 1.38 | 1.23 |
| Weight | - | kg/m ² | 6.0 | 7.6 | 10.9 | 4.6 | 5.5 | 7.4 |
| Linear thermal expansion coefficient | ASTM D696 | ×10 ⁻⁶ /°C | 24 | 24 | 24 | 24 | 24 | 24 |
| Thermal conductivity | ASTM D976 | W/(m·K) | 0.50 | 0.45 | 0.41 | 0.50 | 0.45 | 0.41 |
| Deflection temperature | ASTM D648 | °C | 115 | 116 | 109 | 115 | 115 | 115 |

(2) Specific gravity

The following table is the comparison of specific gravity between various materials.

Table 2-3 Specific gravity

| Material | Specific gravity | Material | Specific gravity |
|-----------------------|------------------|---------------|------------------|
| ALPOLIC/fr | 1.81-1.99 | Granite | 2.9 |
| ALPOLIC | 1.23-1.52 | Glass | 2.5 |
| Aluminum sheet | 2.71 | Acrylic sheet | 1.2 |
| Steel sheet | 7.9 | Gypsum board | 0.86 |
| Stainless steel (304) | 7.9 | Plywood | 0.7-1.0 |

(3) Thermal expansion/contraction

ALPOLICs have the same expansion/contraction rate as aluminum metal. The following table shows the expansion/contraction of various building materials.

Table 2-4 Thermal expansion/contraction

| Material | Linear thermal expansion coefficient, 1/°C | Expansion per 1 meter with 50°C change, mm/m |
|-----------------------|--|--|
| ALPOLIC/fr | 24×10 ⁻⁶ | 1.2 mm |
| ALPOLIC | 24×10 ⁻⁶ | 1.2 mm |
| Aluminum | 24×10 ⁻⁶ | 1.2 mm |
| Steel | 12×10 ⁻⁶ | 0.6 mm |
| Stainless steel (304) | 17×10 ⁻⁶ | 0.9 mm |
| Concrete | 12×10 ⁻⁶ | 0.6 mm |
| Glass | 9×10 ⁻⁶ | 0.5 mm |
| Acrylic sheet | 70×10 ⁻⁶ | 3.5 mm |

(4) Thermal conductivity

ALPOLICs have a lower thermal conductivity than solid metals like aluminum and steel. However, this does not fully reflect the better heat resistance of ALPOLICs, because in an actual building heat transmits not only through thermal conduction but also through thermal radiation and convection. We will discuss overall heat transmission in “5 Applied properties, (1) Heat transmission” in this section.

Table 2-5 Thermal conductivity

| Material | Thermal conductivity, W/(m·K) | Material | Thermal conductivity, W/(m·K) |
|-----------------------|-------------------------------|------------------------|-------------------------------|
| ALPOLIC/fr | 0.41-0.50 | Concrete | 1.6 |
| ALPOLIC | 0.41-0.50 | Brick | 0.28 |
| Aluminum | 210 | Glass | 1 |
| Steel | 45 | Gypsum board | 0.13 |
| Stainless steel (304) | 17 | Rock wool / Glass wool | 0.04 |

(5) Deflection temperature

The deflection temperature of ALPOLICs is approx. 110°C. Therefore, ALPOLICs can resist boiling water for short time, if there is no burden on the ALPOLIC panels. However, in a situation where ALPOLICs will be actually heated, please follow the guidelines below.

If the heating duration is shorter than 30 min, allow 90°C at maximum.

If the heating duration is longer than 30 min, allow 70°C at maximum.

(6) Sound transmission loss

ALPOLICs have a large sound insulation per unit weight, compared to steel sheet, aluminum sheet and plywood. The charts show airborne sound transmission loss measured on ALPOLIC. According to the classification method specified in ASTM E413, STC (standard transmission class) is given as follows:

| Thickness | ALPOLIC | | | ALPOLIC/fr | |
|-----------|---------|-----|-----|------------|-----|
| | 3mm | 4mm | 6mm | 4mm | 6mm |
| STC | 25 | 26 | 26 | 27 | 29 |

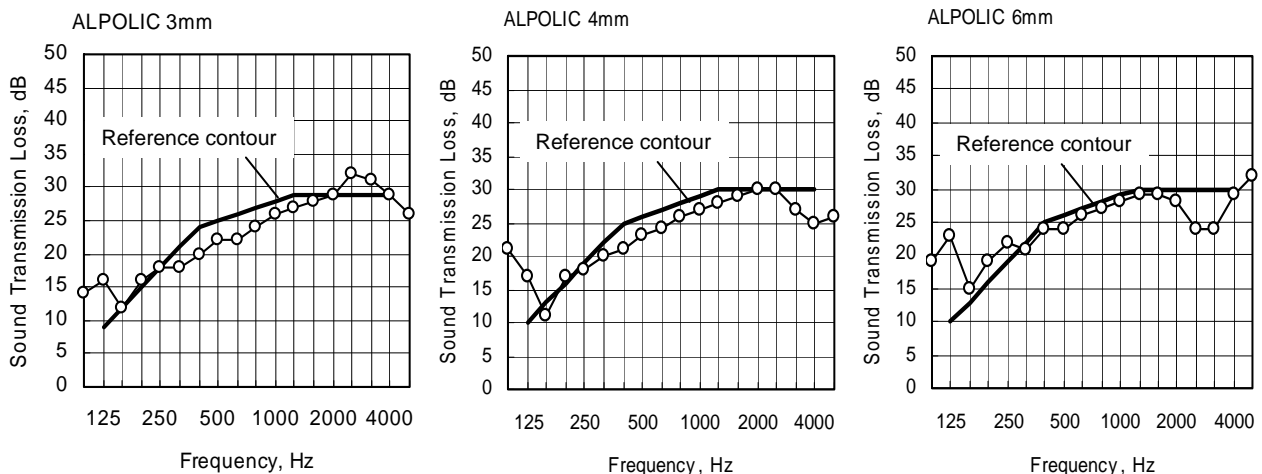

Fig. 2-1 Sound transmission loss

(7) Vibration damping

ALPOLICs have a vibration damping effect that absorbs the vibration energy by converting it into thermal energy.

The chart is ALPOLIC/fr’s vibration damping property in comparison with other metals. As shown in the chart, ALPOLIC/fr has a larger vibration loss than solid metals such as aluminum, steel and stainless steel.

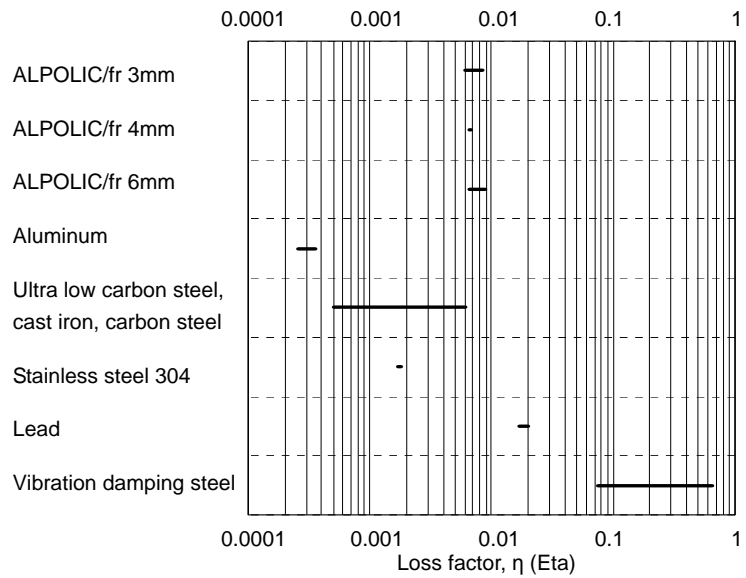

Fig. 2-2 Vibration damping property

Note 1: Test method: JIS G 0602 Test standard for vibration-damping property on laminated damping steel sheets of constrained type

Note 2: On the chart, ALPOLIC/fr’s data are the measured values, and others are cited from Nikkei Mechanical August 1986.

4. Mechanical properties

(1) Mechanical properties of ACM

ALPOLICs have the following mechanical properties as composite panels.

Table 2-6 Mechanical properties of composite panel

| Mechanical property | Method | Unit | ALPOLIC/fr | | | ALPOLIC | | |
|-------------------------|-----------|---------------------------|------------|------|------|---------|------|------|
| | | | 3mm | 4mm | 6mm | 3mm | 4mm | 6mm |
| Tensile strength | ASTM E8 | MPa or N/mm ² | 61 | 49 | 29 | 61 | 48 | 34 |
| 0.2% proof stress | ASTM E8 | MPa or N/mm ² | 53 | 44 | 26 | 58 | 44 | 30 |
| Elongation | ASTM E8 | % | 4 | 5 | 2 | 12 | 14 | 17 |
| Flexural elasticity, E | ASTM C393 | GPa or kN/mm ² | 49.0 | 39.8 | 29.1 | 49.0 | 39.8 | 29.1 |
| Punching shear strength | ASTM D732 | N/mm ² | 36 | 32 | 20 | 28 | 25 | 22 |

(2) Mechanical properties of aluminum skin: Alloy 3105-H14

We use aluminum alloy 3105-H14 for ALPOLICs. Our aluminum alloy 3105-H14 has the following mechanical properties, and we often use these properties for our structural calculation of ALPOLIC panels. Refer to “7. Panel strength” in this section.

Table 2-7 Mechanical properties of aluminum skin

| Mechanical property | Method | Unit | Aluminum 3105-H14 |
|---------------------|---------|---------------------------|-------------------|
| 0.2% proof stress | ASTM E8 | MPa or N/mm ² | 150 |
| Flexural elasticity | ASTM E8 | GPa or kN/mm ² | 70 |

(3) Rigidity and panel weight

Based on the above mechanical properties, we can calculate the flexural rigidity (bending strength) of ALPOLICs. The following table shows the rigidity of ALPOLICs in comparison with solid metals of the same rigidity. As we see in the table, ALPOLICs have high rigidity with lightweight.

Table 2-8 Comparison of rigidity and weight

| ALPOLICs | | | Solid metals of the equivalent rigidity | | | | | |
|---|--------------|--------------------------|---|--------------------------|----------------|---|--------------------------|----------------|
| ALPOLIC & ALPOLIC/fr Specific gravity=1.23-1.99 E=29-49 GPa or kN/mm ² | | | Aluminum Specific gravity=2.71 E=70 GPa or kN/mm ² | | | Stainless steel (304) Specific gravity=7.89 E=190 GPa or kN/mm ² | | |
| Products | Thickness mm | Weight kg/m ² | Thickness mm | Weight kg/m ² | Weight ratio % | Thickness mm | Weight kg/m ² | Weight ratio % |
| ALPOLIC/fr | 3 | 6.0 | 2.7 | 7.3 | 82 | 1.9 | 15.0 | 40 |
| | 4 | 7.6 | 3.3 | 8.9 | 85 | 2.4 | 18.9 | 40 |
| | 6 | 10.9 | 4.5 | 12.2 | 89 | 3.2 | 25.2 | 43 |
| ALPOLIC | 3 | 4.6 | 2.7 | 7.3 | 63 | 1.9 | 15.0 | 31 |
| | 4 | 5.5 | 3.3 | 8.9 | 62 | 2.4 | 18.9 | 29 |
| | 6 | 7.4 | 4.5 | 12.2 | 61 | 3.2 | 25.2 | 29 |

Note (How to read the table): ALPOLIC/fr 3mm is equivalent to 2.7mm thick aluminum in rigidity. Hence, the weight percent of ALPOLIC to solid aluminum is 82%.

(4) Impact resistance

We obtained the following data with the Du-pont method, in which we drop a steel ball from a certain height onto specimen and gauge the dent depth.

Table 2-9 Impact resistance by means of Du-pont test

| Steel ball weight, kg | Height mm | Dent depth, mm | | | | | |
|-----------------------|-----------|----------------|-----|-----|---------|-----|-----|
| | | ALPOLIC/fr | | | ALPOLIC | | |
| | | 3mm | 4mm | 6mm | 3mm | 4mm | 6mm |
| 0.3 | 300 | 0.8 | 0.5 | 0.4 | 1.7 | 0.6 | 0.4 |
| 0.5 | 500 | 1.6 | 1.3 | 1.0 | 1.6 | 1.4 | 0.8 |
| 1.0 | 300 | 1.8 | 1.4 | 1.2 | 2.0 | 1.7 | 1.0 |
| 1.0 | 500 | 3.1 | 1.9 | 1.6 | 2.6 | 2.3 | 1.5 |

Du-pont test instrument



1 kg iron plummet

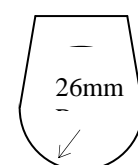

In addition to the above test, we had another impact test using a 1 kg iron plummet in accordance with JIS A 5703. The test includes other sheet

materials for comparison. Refer to the test result attached in “Appendix 4: Impact test with iron plummet” in Section 4. As shown in Appendix 4, ALPOLICs never crack, break or fracture by the impact of the iron plummet.

(5) Bendable limit

We can bend ALPOLICs by means of a press brake or a 3-roll bending machine. In bending with a press brake, the bend-ability depends on ALPOLIC thickness and the core material. ALPOLIC/fr has a larger bendable limit than ALPOLIC has. We define the bendable limit as the radius when wrinkles first appear on the aluminum skin. The smallest bending radius (internal radius) is as follows.

| Thickness | The smallest bendable radius (internal radius) mm | | | |
|-----------|---|--------------|------------|--------------|
| | ALPOLIC/fr | | ALPOLIC | |
| | Transverse | Longitudinal | Transverse | Longitudinal |
| 3mm | 50 | 70 | 40 | 55 |
| 4mm | 80 | 100 | 40 | 55 |
| 6mm | 100 | 140 | 55 | 80 |

Table 2-10 The smallest bending radius with press brake

Note: “Transverse and Longitudinal” shows the bending direction toward the roll (coating) direction.

In 3-roll bending, the bendable limit depends on the bending roll diameter, roll length and type of bending machine. But the bendable limit of ALPOLIC 4mm is approx. 300mm in radius in most 2500mm long machines.

5. Applied properties

(1) Heat transmission

ALPOLICs help to reduce the energy consumption of buildings. When we use ALPOLICs for external or internal claddings, the air space between ALPOLICs and the backing wall forms a thermal insulation layer and increases the wall system’s energy conservation performance.

Generally, heat transmits through a building wall with three steps of R1 to R3 shown in the diagram.

R1: Heat transmission of interface between the outer air and the wall

R2: Heat flow inside the wall by thermal conductance

R3: Heat transmission of interface between the wall and the inner air

The overall heat transmission is the sum of R1 to R3.

Fig 2-3 Heat Transmission

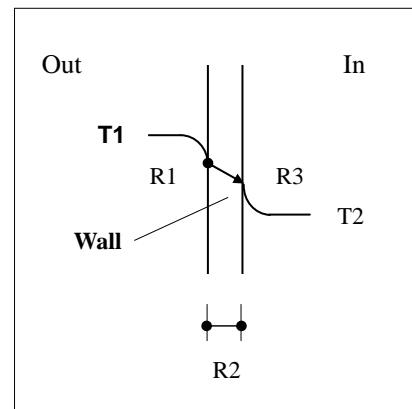

In the same manner, we can calculate the heat transmission of actual wall systems. Table 2-11 is a calculated example. The calculated value is called the heat transmission coefficient, U-value ($W/m^2 \cdot K$) or K-value ($kcal/m^2 h \cdot ^\circ C$). A lower U-value means less heat flow or higher heat resistance. As we can see in the table, covering the wall with ALPOLIC cladding improves the thermal insulation effect by

approx. 15%, and installing a heat insulation material behind ALPOLIC increases the insulation effect by more than two times.

Table 2-11 Heat transmission through external wall

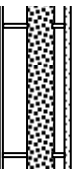
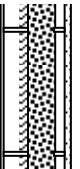
| Wall system, wall component and its thickness | RC wall only | | | ALPOLIC cladding | | | ALPOLIC + Heat insulation | | |
|---|---|----|--|---|----|--|---|----|--|
| | out | in | | out | in | | out | in | |
| |  | | RC wall (100) Air space (50) Gypsum board (12) |  | | ALPOLIC (4) Air space (100) RC wall (100) Air space (50) Gypsum board (12) |  | | ALPOLIC (4) Air space (75) Glass wool (25) RC wall (100) Air space (50) Gypsum board (12) |
| Calculated U-value | 2.5 W/m ² ·K | | | 2.1 W/m ² ·K | | | 0.92 W/m ² ·K | | |

Note: We can convert U-value into K-value with the following equation.

$$K\text{-value (kcal/m}^2\text{h}^\circ\text{C)} = 0.86 \times U\text{-value (W/m}^2\text{·K)}$$

(2) Non-permeability

ALPOLICs are non-permeable. Under humid atmospheric conditions, ALPOLICs do not absorb moisture at all. The following is the test result of the freezing and thawing cycle test, which confirms the complete non-permeability of ALPOLICs.

- a. Freezing and thawing test
- b. Exposure cycle: -20°C×1.0hrs for freezing and +10°C×1.5hrs for thawing
- c. Test result:

After 300 cycles, the sample does not show any change in weight, thickness or appearance.

Note: If you use ALPOLICs in a humid condition like in a bathroom where the edge of the panel may be always wet, it is important to design the fixing detail to drain the moisture and to keep the edge dry. Please consult local distributors or our office about practical methods of suitable fixing details.

(3) Fire performance

ALPOLIC/fr is a fire-safe material that passes mandatory requirements for exterior and interior use in most countries. Although the core material does contain a small amount of combustible polyethylene, the main mineral ingredient does not permit the proliferation of flame and restricts the development of smoke detrimental to evacuation activities. ALPOLIC, on the other hand, is composed of 2 skins of aluminum that retard the rapid spread of fire, although less effectively than ALPOLIC/fr.

a. Fire test result of ALPOLIC/fr

We have had extensive fire tests of ALPOLIC/fr in accordance with requirements in various countries. ALPOLIC/fr has passed the following fire tests.

Table 2-12 Fire tests for general and external cladding material

| Country | Test standard | ALPOLIC/fr specimen | Results & classification |
|----------------|---|---------------------|---------------------------------|
| EU | EN 13823, EN ISO 11925-2, EN 13501-1 | 4mm, 6mm | Class B |
| United Kingdom | BS476 Part 7 | 4mm, 6mm | Class 1 |
| | BS476 Part 6 | 4mm, 6mm | Class 0 |
| Germany | DIN4102 Part 1 | 4mm, 6mm | Class B1 |
| USA | NFPA 259-93 British Thermal Unit | 4mm | Passed |
| | ASTM D1781-76 Climbing Drum Peel Test | 4mm, 6mm | Passed |
| | ASTM E84, Steiner Tunnel Test | 4mm, 6mm | Class A / Class 1 |
| | ASTM E-108, Modified | 4mm | Passed |
| | UBC 26-9 & NFPA 285, ISMA Test (Intermediate Scale Multi-story Apparatus) | 4mm, 6mm | Passed |
| Canada | CAN/ULC-S 134-92, Full-scale Exterior Wall Fire Test | 4mm | Passed |
| China | GB8625, GB8626 & GB8627 | 4mm | Class B1 |
| Japan | Heat Release Test for Non-combustible Material (ISO 5660-1) | 4mm, 6mm | Passed. Certificate No. NM-1933 |

Table 2-13 Fire tests for other categories

| Category | Country | Test Standard | ALPOLIC/fr specimen | Results & classification |
|----------------------------|---------|--|---------------------|---------------------------------|
| Fire resistant rating wall | USA | ASTM E119, 1-hr Fire Rating and 2-hr Fire Rating | 4mm | Passed |
| Roof material | USA | ASTM E108, Fire Test for Roof Covering | 4mm | Passed Class A |
| Interior material | USA | UBC 26-3, Interior Room Corner Test | 4mm | Passed |
| | | Combustion Toxicity Test, New York State Uniform Fire Prevention and Building Code | 4mm | Passed |
| | Japan | Heat Release Test for Non-combustible Material (ISO 5660-1) & Toxicity Gas Test | 3, 4, 6mm | Passed. Certificate No. NM-1933 |

c. Comments on the fire tests of ALPOLIC/fr

(i) External cladding

The ISMA Test (Intermediate Scale Multi-story Apparatus, UBC 26-9 & NFPA 285) is a mandatory test for external cladding in US building codes. This test is a simulation test to check the fire propagation using 2-story mock-up model installed with the building material specimen.

A big concern in external cladding is the upward extension of flames over the vertical exterior wall, as shown in Fig. 2-4. Through the ISMA test in Fig. 2-5, we can evaluate the fire extension performance over the external cladding in a controlled environment. ALPOLIC/fr passes this test and has an approval for external claddings without height restrictions.

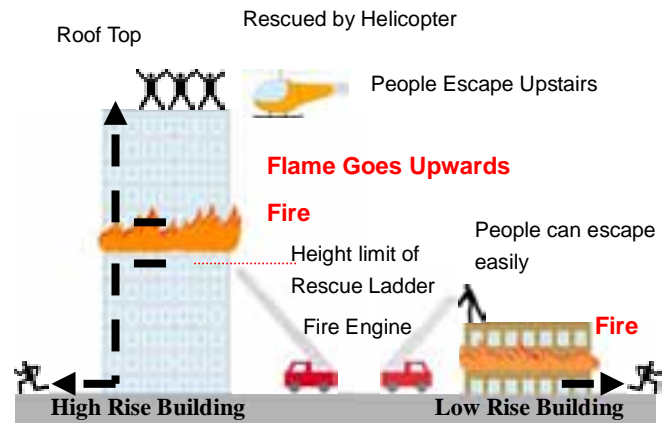
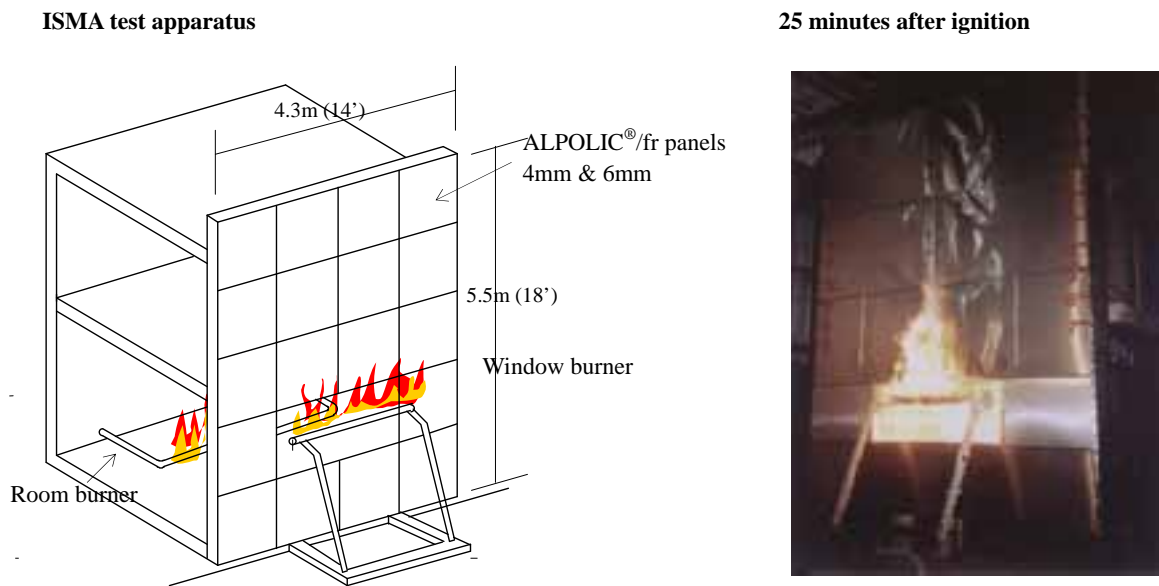

Fig. 2-4 Evacuation from fire

Fig. 2-5 Intermediate-scale Multistory Apparatus



(ii) Roof covering material

ALPOLIC/fr passes the fire tests in ASTM E108, which examines the fire performance as roof covering materials. It consists of three types of fire tests: a burning brand test, an intermittent flame test and a spread of flame test.

Fig. 2-6 ASTM E108 Fire test for roof covering
Intermittent flame test & spread of flame test

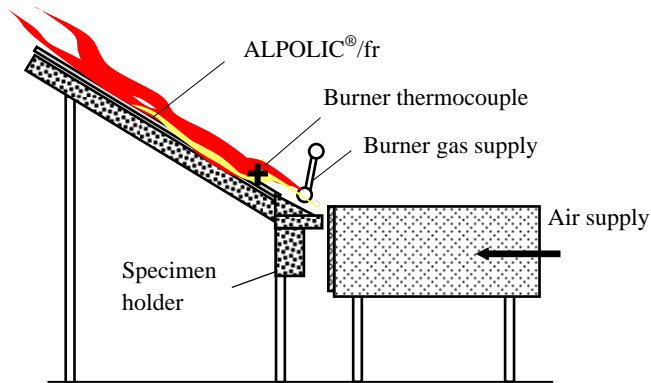

Burning brand test



(iii) Interior material

UBC26-3 Interior Room Corner Test is a fire test that verifies the hazardous flashover performance of interior finishing materials. If a fire is generated at a corner of a room, the flame will grow gradually until a certain critical point called a flashover. When the fire has reached the flashover point, it suddenly expands toward the opening door like an explosion. This test simulates this phenomenon and examines the flashover performance of interior finishing materials.

Fig. 2-7 UBC26-3 Interior Room Corner Test

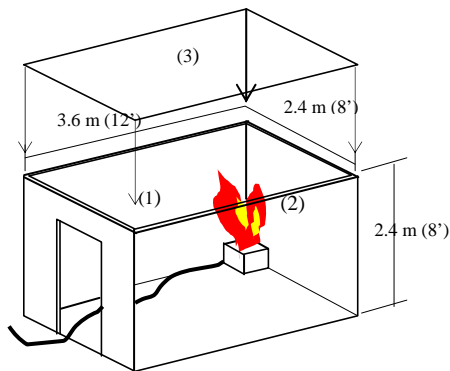

Testing conditions:
 Heater: Gas burner or 30lb wood crib
 Time: 15 min
 The interior is finished with the testing material
 (1) Side wall, (2) Front wall, (3) Ceiling: Optional

Example of Interior Room Corner Test



(iv) Fire approval in Japan

ALPOLIC/fr passes Japan's cone calorimeter test ISO5660-1, a standard fire test for building material classification. It also passes Japan's toxicity gas test and has approval as a non-combustible material for external cladding, roof covering and interior with Certificate No. NM-1933.

Fig. 2-8 Fire test in Japan, ISO 5660-1



6. Coating performance

(1) Color variation

ALPOLICs have a coating finish of Lumiflon-based fluorocarbon paints as standard. The coating has four types of colors: Solid (Enamel) Colors, Metallic Colors, Sparkling Colors and NaturArt Series (stone, timber, metal, and abstract). Refer to the Color Chart for the standard colors. All types of colors are produced in our continuous coil coating line with Lumiflon-based fluorocarbon paints. In addition to the standard colors in the Color Chart, custom colors are available, subject to minimum quantities and color match. Contact local distributors or our office for custom color request.

Note: ALPOLICs are finished with Lumiflon-based fluorocarbon paint as standard, but polyester and other coatings are also available as option. Refer to “Appendix 2: Optional coatings” in Section 4 for details.

(2) Coating system

Our Lumiflon-based fluorocarbon coating includes three types of coating systems.

a. Solid (enamel) colors

- i) 2-coat 2-bake system; the total dry film thickness is 25 microns minimum, and
- ii) 3-coat 3-bake system; the total dry film thickness is 33 microns minimum with a top clear coating.

b. Metallic colors, Sparkling colors, and Prismatic colors are a 3-coat, 3-bake system, and the total dry thickness is 28 microns minimum.

c. NaturArt Series (Stone, Timber, Metal, and Abstract) are coated with a unique image transfer process, and the total dry film thickness is 45 microns minimum.

Note: Lumiflon-based fluorocarbon coating has a coating warranty of 10 years.

(3) Coating performance

Lumiflon-based fluorocarbon paint is known for its high weatherability. We apply this paint in our continuous coil coating line for all finishing types, which ensures uniform quality of the coating. The Lumiflon-based fluorocarbon coating meets the following criteria.

Fig. 2-9 3-coat, 3-bake system for Metallic Colors

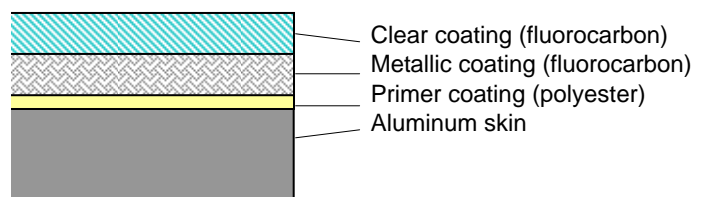

Table 2-15 Coating performance

A. General properties

| Dry film property | Test method | Criteria |
|--|--------------------------------|-----------------|
| Gloss (60°) | ASTM D523-89 | 15 to 80% |
| Formability (T-bend) | NCCA II-19 ASTM D1737-62 | 2T, no cracking |
| Reverse impact-crosshatch | NCCA II-5 | No pick off |
| Hardness-pencil | ASTM D3363-92a | H |
| Adhesion | | |
| Dry | ASTM D3359, method 8 | No pick off |
| Wet | 37.8°C, 24 hrs. | No pick off |
| Boiling water | 100°C, 20 min. | No pick off |
| Abrasive resistance | ASTM D968-93 (Falling sand) | 40 liters/mil |
| Chemical resistance | | |
| Muriatic acid, 10% HCl, 72hrs | ASTM D1308-87 | No change |
| Sulphuric acid, 20% H ₂ SO ₄ , 18hrs | ASTM D1308-87 | No change |
| Sodium hydroxide, 20% NaOH, 1hr | ASTM D1308-87 | No change |
| Mortar, pat test, 38°C, 24hrs | AAMA 2605 | No change |
| Detergent, 3% solution, 38°C, 72hrs | ASTM D2248-93 | No change |

B. Weatherability

| Dry film property | Test method | Criteria |
|-----------------------|---------------|--|
| Weather-o-meter test | | |
| Colour retention: | ASTM D2244-93 | Maximum 5 units after 4000 hrs. |
| Gloss retention: | ASTM D523-89 | 70% after 4000 hrs. |
| Chalk resistance: | ASTM D4214-89 | Maximum 8 units after 4000 hrs. |
| Salt spray resistance | ASTM B117-90 | Blister-10, scribe-8, after 4000 hrs, 35°C salt fog |
| Humidity-thermal | ASTM D2246-87 | No blister, no cracking After 15 cycles of 38°C 100% RH for 24hrs and -23°C for 20hrs |
| Humidity resistance | ASTM D2247-94 | No change After 4000 hrs, 100% RH, 35°C |

7. Panel strength

When we use ALPOLIC panels outdoors, the panels must withstand the wind load. When the wind blows toward the panels, the wind will exert a positive pressure on them. On the other hand, a negative wind load will cause suction on the panels. These wind loads will cause deflection of the panels to a certain extent, and if the deflection is small enough, the panels will return to the original position when the wind load is off. We normally confirm the adequacy of the panel strength by calculating the strength under given conditions.

Fig. 2-10 Wind load on ALPOLIC panels

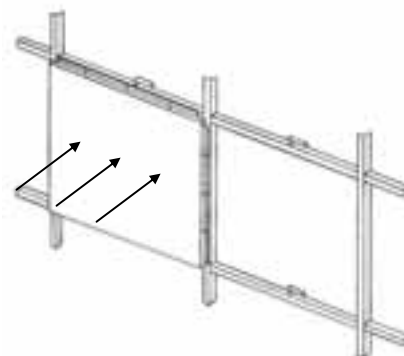

(1) Calculation of permanent deformation

In calculation, we assume that the strength of ALPOLIC panels lies in its aluminum skins. Namely, if the stress exerted on the aluminum skins is smaller than the permissible value, permanent deformation will not occur. In this calculation, the permissible value is given as 0.2% proof stress (or yield strength) of aluminum skin divided by a safety factor. 0.2% proof stress depends on the aluminum alloy and the hardening condition. The following aluminum alloy is used in ALPOLICs:

Table 2-16 0.2% proof stress value for calculation of permanent deformation

| ALPOLIC/fr and ALPOLIC | Aluminum alloy and hardening condition | 0.2% proof stress |
|------------------------|--|------------------------------|
| 3mm, 4mm and 6mm | 3105-H14 | 150 MPa or N/mm ² |

Note: In our calculation, we use the same parameters and equations for both ALPOLIC/fr and ALPOLIC, because we ignore the role of the core in our calculation. As a result, we obtain the same calculation result with ALPOLIC/fr and ALPOLIC.

If the calculated stress becomes larger than the permissible limit, further study is required to lessen the stress. One solution is to reinforce the panel with stiffener. Generally, the panel strength depends on the following environmental and geometrical factors in addition to the 0.2% proof stress of the aluminium skin:

- A. Wind load
- B. ALPOLIC total thickness
- C. Supporting condition
- D. ALPOLIC panel size

The actual calculation method is outlined in “Appendix 5: Panel strength” in Section 4. If you need a structural calculation, please contact local distributors or our office.

(2) Calculation of panel deflection

Permanent deformation is a completely undesirable condition. On the other hand, panel deflection depends on the requirements of the project. If the maximum deflection is specified in the project, we have to study whether the expected deflection conforms to the project specifications or not. In this calculation, we use the following flexural elasticity as a composite panel.

Table 2-17 Flexural elasticity (E) for calculation of deflection

| ALPOLIC/fr and ALPOLIC | Flexural elasticity, E GPa or kN/mm ² |
|------------------------|---|
| 3mm | 49.0 |
| 4mm | 39.8 |
| 6mm | 29.1 |

The calculation method of panel deflection is outlined in “Appendix 5: Panel strength” in Section 4. If

you need a deflection calculation, please contact local distributors or our office.

(3) Strength of joining holes

When suction pressure is exerted on ALPOLIC panels, the joining hole of the rivet or screw must withstand the tension. Otherwise, the joining hole will tear and the panel will separate from the structure.

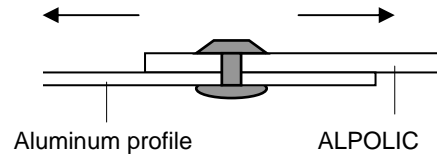

In actual installation work, the position of joining hole is important. When the hole is positioned in the proximity of panel edge, its strength will be lessened and may be unsatisfactory. Normally, the distance from hole-center to panel edge (e) should be larger than twice the hole-diameter (D). Namely, $e > 2 \times D$. Refer to “Appendix 6: Strength of joining hole” in Section 4.

Note: In order to prevent from galvanic corrosion of ALPOLIC, use rivets, screws or bolts/nuts made of aluminum or stainless steel for joining. If ALPOLIC is connected to dissimilar metals like steel, lay a coating film 25 microns (1 mil) or thicker on the metal.

(4) Strength of sub-structure

Normally, ALPOLIC panels are installed on a sub-structure made of steel or aluminum. The sub-structure must withstand the wind load as well as ALPOLIC panels do. The strength of sub-structure depends on the following factors:

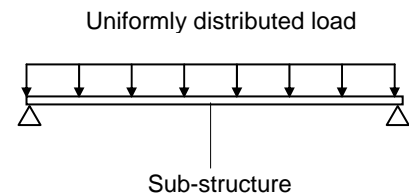

- A. Rigidity of sub-structure (material and section)
- B. Supporting (anchoring) interval of sub-structure
- C. Wind pressure loading on sub-structure

As the sub-structure is normally deemed to be a part of structure, the maximum deflection must meet the $L/200$ rule: namely, the maximum deflection must be smaller than the supporting interval divided by 200 (or 0.5% of supporting interval).

8. Lightning and earthquake

(1) Lightning

In the event that a lightning should strike an ALPOLIC panel installed on a building, what will happen on the panel and the building? According to our study, as far as the aluminum skin is connected to the ground earth through the sub-structure system, the electricity will be discharged to the ground earth. The electric conduction of the sub-structure system is large enough to discharge the lightning energy, and accordingly,

Fig. 2-11, Lightning and external cladding

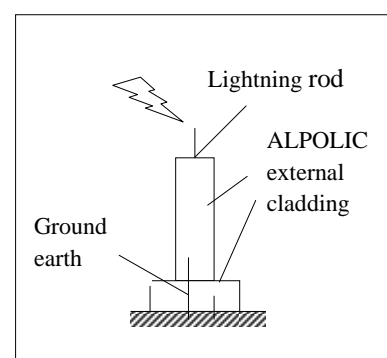

considerable damage will not occur in most of the ALPOLIC panels in the building. But the impact of the lightning is so intense that the struck panel itself will be completely damaged.

(2) Earthquake

In those areas where earthquakes are possible, the external panels must withstand the shearing force parallel to the panel surface. According to our test in accordance with JIS A1414 “Deforming test of non-bearing wall panel due to shearing force parallel to panel surface,” the displacement is absorbed in ALPOLIC’s deflection, and ALPOLIC panels are completely restored to the original position when the displacement is eliminated. The test has shown that ALPOLIC panels withstand the shearing forces with a displacement range between 1/400 and 1/50.

Fig. 2-12 Test of shearing force for earthquakes

